



www.genswiss.com
sales@genswiss.com
1-413-562-4800

Signature Series High Precision Saw Arbors

Standard Precision TIR Less Than .0005in
Ultra Precision TIR Less Than .0002in



Custom Made

5015 Series
2-in-1 Combo

5030 Series
Standard Metric

5025 Series
Ultra Precision

5020 Series
Flange Type

www.genswiss.com

1-(413)-562-4800

sales@genswiss.com

6 Old Stage Road , Westfield, MA 01085

Combination Saw Arbors - 5015 Series

GenSwiss combination arbors are made from pre hardened material and exemplify what it means to be called "Swiss Precision". The addition of the combined mill or center drill provides additional tool capacity and setup flexibility . TIR measured at less than .0002". Made in the USA.

Tool Bore (B)	Hub		Body		Shaft		Nut		Item No.	Description
	D1	L1	D2	L2	D3	L3	D4	L4		
3mm	.2500in	.125in	.375in	.625in	.250in	1.375in	.375in	.375in	5015-000109	SAC-N250-250118
	.3120in	.125in	.375in	.625in	.312in	1.375in	.375in	.375in	5015-000111	SAC-N312-312118
	.3748in	.115in	.500in	.625in	.375in	1.375in	.500in	.374in	5015-000114	SAC-N375-375118
	8mm	3mm	9.5mm	16mm	8mm	35mm	9.5mm	9.5mm	5015-000113	SAC-N315-315118
	10mm	3mm	12.7mm	16mm	10mm	35mm	12.7mm	9.5mm	5015-000115	SAC-N394-394118
.1250in	.2500in	.125in	.375in	.625in	.250in	1.375in	.375in	.375in	5015-000108	SAC-N250-250125
	.3120in	.125in	.375in	.625in	.312in	1.375in	.375in	.375in	5015-000110	SAC-N312-312125
	.3748in	.125in	.500in	.625in	.375in	1.375in	.500in	.374in	5015-000101	SAC-N375-375125
	8mm	3mm	9.5mm	16mm	8mm	35mm	9.5mm	9.5mm	5015-000105	SAC-N315-315125
	10mm	3mm	12.7mm	16mm	10mm	35mm	12.7mm	9.5mm	5015-000106	SAC-N394-394125
.1875in	.3120in	.125in	.375in	.625in	.312in	1.375in	.375in	.375in	5015-000112	SAC-N312-312187
	.3748in	.125in	.500in	.625in	.375in	1.375in	.500in	.374in	5015-000102	SAC-N375-375187
	8mm	3mm	9.5mm	16mm	8mm	35mm	9.5mm	9.5mm	5015-000100	SAC-N315-315187
	10mm	3mm	12.7mm	16mm	10mm	35mm	12.7mm	9.5mm	5015-000103	SAC-N394-394187

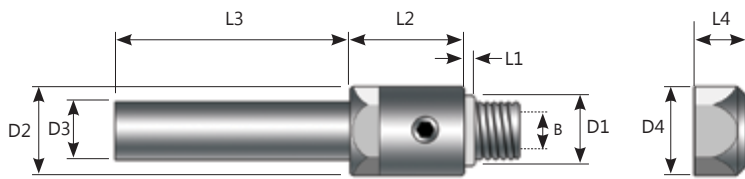

Custom Slitting Saw Arbors

GenSwiss has the capability to assist with the engineering and manufacture of special gang slotting arbors that also feature the option of holding an end mill, spot drill or other small round shank rotary tool.

Some features we can provide:

- Spacers for gang slotting with multiple blades.
- Custom hub widths (L1 dim.) for oversize blade thicknesses.
- Optional shank sizes for special applications.



Ti-Loc® ER Taper Integrated Saw Arbors

Introducing the newest GenSwiss signature product, the Ti-Loc® taper integrated arbor. These high precision arbors are designed to work with virtually any live tool spindle that employs the dual angle ER collet system (DIN6499). Ideal for when repeatability of positioning and rigidity is required. Our BEST solution for holding saws in your Swiss lathes. Typical TIR is under .0002". Made in the USA

- Direct Mount to ANY ER16 Taper Live Tool Position
- Reduces Tolerance "Stacking" for Better TIR
- Increases Rigidity During Slitting Operations
- Taper and Saw Blade Journal are GROUND for max. Precision

**Now Available
For Sizes ER11 ER16 & ER20!!**



Patented

Flange Mount Metric Saw Arbors - 5020

These metric flanged saw arbors provide maximum saw balance and stability with the flange mount design. The unique design applies pressure to the outward edge of the flange ensuring the greatest gripping power at the outer most edge to prevent slipping. Uses countersunk screw and flange washer to apply holding force. Measured TIR is less than .0002".

Item No.	Description	D1	L1	D2	L2	D3	L3
5020-000100	SAF-050010-503809-M4F	5.00mm	1.00mm	9.00mm	12.00mm	5.00mm	38.0mm
5020-000101	SAF-050010-703812-M4F	5.00mm	1.00mm	12.00mm	12.00mm	7.00mm	38.0mm
5020-000103	SAF-080016-703818-M5F	8.00mm	1.60mm	18.00mm	13.00mm	7.00mm	38.0mm
5020-000104	SAF-080016-104514-M5F	8.00mm	1.60mm	14.00mm	14.00mm	10.00mm	45.0mm
5020-000105	SAF-080040-104514-M5F	8.00mm	4.00mm	14.00mm	14.00mm	10.00mm	45.0mm
5020-000106	SAF-130025-134522-M6F	13.00mm	2.50mm	22.00mm	16.00mm	13.00mm	45.0mm
5020-000107	SAF-160025-134525-M6F	16.00mm	2.50mm	25.00mm	16.00mm	13.00mm	45.0mm
5021-000002	SAF-095011-042511-C11	9.50mm	1.10mm	11.40mm	19.10mm	4.00mm	25.4mm
5021-000001	SAF-100025-071918-C15	10.00mm	2.50mm	19.00mm	14.00mm	7.00mm	19.0mm
5021-000004	SAF-100025-071918-C18	10.00mm	2.50mm	19.00mm	14.00mm	7.00mm	19.0mm
5021-000005	SAF-130025-071919-C19	13.00mm	2.50mm	19.00mm	14.00mm	7.00mm	19.0mm
5021-000006	SAF-047013-473895-M3F	4.76mm	1.30mm	9.50mm	11.96mm	4.76mm	38.0mm
5021-000007	SAF-063013-633811-M4F	6.35mm	1.30mm	11.40mm	11.96mm	6.35mm	38.0mm
5021-000008	SAF-079016-793816-M5F	7.94mm	1.65mm	15.90mm	13.60mm	7.94mm	38.0mm
5021-000009	SAF-095025-953816-M6F	9.53mm	2.49mm	15.90mm	13.80mm	9.53mm	38.0mm

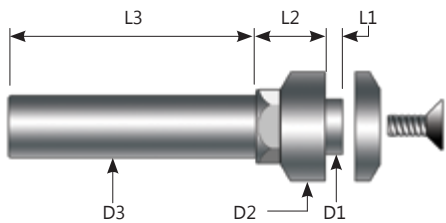

Precision Saw Arbors - 5025 Series

When ULTRA Precision is required, our most popular SAP (under .0002" TIR) grade arbors are suggested as they are held to stringent quality standards required by discerning Swiss-type machinists. SAPE arbors offer multi saw configurations. Made in the USA.

ULTRA Precision TIR < .0001"		D1	L1	D2	L2	D3	L3	D4	L4	Includes Spacer?
5025-000102	SAP-N1250-1250	.1248in	.025in	.197in	.500in	.125in	1.0in	.197in	.185in	No
5025-000103	SAP-N1875-1875	.1874in	.045in	.315in	.500in	.187in	1.4in	.316in	.305in	No
5025-000104	SAP-N2500-2500	.2498in	.045in	.394in	.500in	.250in	1.4in	.394in	.305in	No
5025-000105	SAP-N3125-3125	.3124in	.045in	.451in	.500in	.312in	1.4in	.451in	.305in	No
5025-000106	SAP-N3750-3750	.3749in	.045in	.500in	.500in	.375in	1.4in	.500in	.305in	No
5025-000107	SAP-N5000-5000	.4999in	.052in	.625in	.500in	.500in	1.4in	.625in	.305in	No
5025-000113	SAPE-N2500-2500-6.0	.2500in	.049in	.453in	.500in	.250in	1.4in	.394in	.349in	Yes

Metric Shanks TIR < .0001"		D1	L1	D2	L2	D3	L3	D4	L4	Includes Spacer?
5025-000100	SAP-N0500-0500	5mm	1.0mm	8.0mm	11.5mm	5mm	38.0mm	8.0mm	6.35mm	No
5025-000101	SAP-N0800-0800	8mm	1.2mm	11.5mm	11.3mm	8mm	35.0mm	11.5mm	8.0mm	No
5025-000109	SAP-N1000-1000	10mm	1.2mm	13.5mm	16.6mm	10mm	30.0mm	13.5mm	8.0mm	No
5025-000111	SAPE-N0500-0500-6.0	5mm	1.2mm	8.0mm	12.7mm	5mm	35.6mm	8.0mm	8.85mm	Yes
5025-000112	SAPE-N0800-0800-6.0	8mm	1.2mm	10.0mm	12.7mm	8mm	35.6mm	11.5mm	8.85mm	Yes

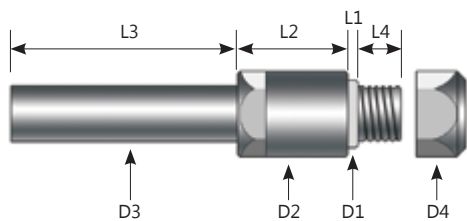

SAPE Arbor Shown.
Included Spacers Allow For
Double Saw Configuration.

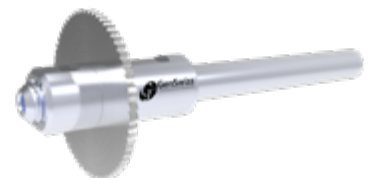

SAP Arbor Shown.

NEW SIZES Available!

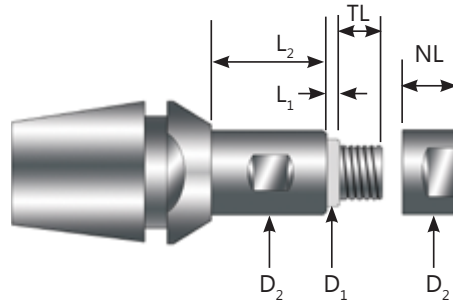

TIR Held to .0002" or Better
 Repeatable Positioning of Saw Edge
 Ground ER Taper and Saw Journal
 Integrated ER Taper For Maximum Rigidity

ER11 Saw Arbors

Item No.	Description	D ₁	D ₂	L ₁	L ₂	NL	TL
4800-000205	SAT-11-3.00-064100	3	6.4	1.27	10	5	5
4800-000206	SAT-11-3.00-064140	3	6.4	1.27	14	5	5
4800-000207	SAT-11-3.00-064190	3	6.4	1.27	19	5	5
4800-000223	SAT-11-3.00-064250	3	6.4	1.27	25	5	5
4800-000208	SAT-11-3.18-064100	.125"	6.4	1.27	10	5	5
4800-000209	SAT-11-3.18-064140	.125"	6.4	1.27	14	5	5
4800-000210	SAT-11-3.18-064190	.125"	6.4	1.27	19	5	5
4800-000224	SAT-11-3.18-064250	.125"	6.4	1.27	25	5	5
4800-000212	SAT-11-4.76-080100	.187"	8	1.27	10	5	6.35
4800-000213	SAT-11-4.76-080140	.187"	8	1.27	14	5	6.35
4800-000214	SAT-11-4.76-080190	.187"	8	1.27	19	5	6.35
4800-000225	SAT-11-4.76-080250	.187"	8	1.27	25	5	6.35
4800-000216	SAT-11-5.00-080100	5	8	1.27	10	5	6.35
4800-000217	SAT-11-5.00-080140	5	8	1.27	14	5	6.35
4800-000218	SAT-11-5.00-080190	5	8	1.27	19	5	6.35
4800-000226	SAT-11-5.00-080250	5	8	1.27	25	5	6.35
4800-000279	SAT-11-5.00-080100-3.8	5	8	1.27	25	5	6.35
4800-000220	SAT-11-6.00-080100	6	8	1.27	10	6.35	8
4800-000221	SAT-11-6.00-080140	6	8	1.27	14	6.35	8
4800-000222	SAT-11-6.00-080190	6	8	1.27	19	6.35	8
4800-000227	SAT-11-6.00-080250	6	8	1.27	19	6.35	8

ER16 Saw Arbors

Item No.	Description	D ₁	D ₂	L ₁	L ₂	NL	TL
4800-000146	SAT-16-3.00-064180	3	6.35	1.27	18	6.35	6.5
4800-000147	SAT-16-3.00-064240	3	6.35	1.27	24	6.35	6.5
4800-000148	SAT-16-3.18-064180	.125"	6.35	1.27	18	6.35	6.5
4800-000149	SAT-16-3.18-064240	.125"	6.35	1.27	24	6.35	6.5
4800-000151	SAT-16-4.76-095180	.187"	9.53	1.27	18	6.35	6.5
4800-000154	SAT-16-4.76-095240	.187"	9.53	1.27	24	6.35	6.5
4800-000152	SAT-16-5.00-095180	5	9.5	1.27	18	6.35	6.5
4800-000185	SAT-16-5.00-095240	5	9.5	1.27	24	6.35	6.5
4800-000156	SAT-16-6.00-095180	6	9.53	1.27	18	6.35	6.5
4800-000159	SAT-16-6.00-095240	6	9.53	1.27	24	6.35	6.5
4800-000158	SAT-16-6.35-095180	.250"	9.53	1.27	18	6.35	6.5
4800-000162	SAT-16-6.35-095240	.250"	9.53	1.27	24	6.35	6.5
4800-000190	SAT-16-7.94-100180	.312"	10	1.27	18	6.35	6.5
4800-000168	SAT-16-7.94-100240	.312"	10	1.27	24	6.35	6.5
4800-000294	SAT-16-7.94-100500	.312"	10	1.27	24	6.35	6.5
4800-000191	SAT-16-8.00-100180	8	10	1.27	18	6.35	6.5
4800-000186	SAT-16-8.00-100240	8	10	1.27	24	6.35	6.5

All Ti-Loc Saw Arbors Include (2)
 Saw Clamping Nuts

ER20 Saw Arbors

Item No.	Description	D ₁	D ₂	L ₁	L ₂	NL	TL
4800-000232	SAT-20-3.00-064180	3	6.35	1.27	18	6.35	6.5
4800-000233	SAT-20-3.00-064300	3	6.35	1.27	30	6.35	6.5
4800-000236	SAT-20-3.18-064180	.125"	6.35	1.27	18	6.35	6.5
4800-000237	SAT-20-3.18-064300	.125"	6.35	1.27	30	6.35	6.5
4800-000242	SAT-20-4.76-095180	.187"	9.53	1.27	18	6.35	7.75
4800-000243	SAT-20-4.76-095300	.187"	9.53	1.27	30	6.35	7.75
4800-000246	SAT-20-5.00-095180	5	9.53	1.27	18	6.35	7.75
4800-000247	SAT-20-5.00-095300	5	9.53	1.27	30	6.35	7.75
4800-000252	SAT-20-6.00-095180	6	9.53	1.27	18	6.35	8.5
4800-000253	SAT-20-6.00-095300	6	9.53	1.27	30	6.35	8.5
4800-000257	SAT-20-6.35-095180	.250"	9.53	1.27	18	6.35	7.75
4800-000258	SAT-20-6.35-095300	.250"	9.53	1.27	30	6.35	7.75
4800-000262	SAT-20-7.94-100180	.312"	9.53	1.27	18	6.35	7.75
4800-000263	SAT-20-7.94-100300	.312"	9.53	1.27	30	6.35	7.75
4800-000266	SAT-20-8.00-100180	8	10	1.27	18	6.35	7.75
4800-000267	SAT-20-8.00-100300	8	10	1.27	30	6.35	7.75
4800-000270	SAT-20-9.52-125180	.375"	12.5	1.27	18	7	9
4800-000271	SAT-20-9.52-125300	.375"	12.5	1.27	30	7	9
4800-000274	SAT-20-10.0-125180	10	12.5	1.27	18	7	9
4800-000275	SAT-20-10.0-125300	10	12.5	1.27	30	7	9



Nut With Smaller Width For
 Clamping Thicker Saws

Standard Nut For
 Clamping Thin Saws

**Call 413-562-4800 for
 Replacement Parts**

Premium Swiss-Made Solid Carbide Saw Blades

GenSwiss carries a full line of Solid Carbide Slitting Saws directly imported from Switzerland. Available from stock in either fine and extra-fine tooth configurations with tooth counts ranging from 40-120 teeth per saw.

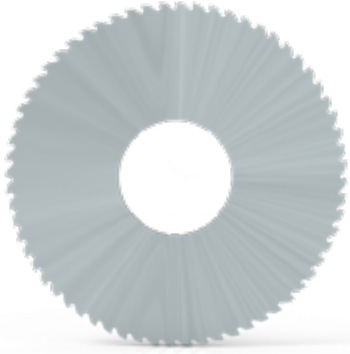

Our Solid Carbide Saws Feature:

- Precision Ground Accuracy
- Superior Surface Finish
- High Tooth Count for Cutting Hard Metals
- Hollow Ground Side Clearance
- Full Radius, V-Cutter, & Staggered Versions Available

Saw Blade Nomenclature Example: **SSM-2508-100048G**

Slitting Saw Metric

25mm OD

8mm ID

1.00mm wide

48 teeth



Width

Metric Carbide Saws Fine Tooth Configuration

OD ID	15mm 5mm	20mm 5mm	25mm 5mm	25mm 8mm	30mm 5mm	30mm 8mm	40mm 10mm
0.10mm (.0039in)	64-80	80-100	80-120	80-120	100-160	100-160	100-160
0.15mm (.0059in)	64-80	80-100	80-120	80-120	100-160	100-160	100-160
0.20mm (.0078in)	64-80	80-100	80-120	80-120	100-160	100-160	100-160
0.25mm (.0098in)	64-80	80-100	80-120	80-120	100-160	100-160	100-160
0.30mm (.0118in)	64-80	80-100	80-120	80-120	100-120	100-120	100-160
0.35mm (.0137in)	64-80	80-100	80-120	80-120	100-120	100-120	100-160
0.40mm (.0157in)	80	80-100	80-120	80-120	100-120	100-120	100-160
0.50mm (.0196in)	80	80-100	80-120	80-120	100-120	100-120	100-160
0.55mm (.0216in)	80	80-100	80-120	80-120	100-120	100-120	100-160
0.60mm (.0236in)	80	80-100	80-120	80-120	100-120	100-120	100-160
0.70mm (.0275in)	80	80-100	80-120	80-120	100-120	100-120	100-160
0.80mm (.0314in)	80	80-100	80-100	80-100	100-120	100-120	100-160
0.85mm (.0334in)	80	80-100	80-100	80-100	100-120	100-120	100-160
0.90mm (.0354in)	80	80-100	80-100	80-100	100-120	100-120	100-160
1.00mm (.0393in)	80	80-100	80-100	80-100	100-120	100-120	100-160
1.05mm (.0413in)	80	80-100	80-100	80-100	100-120	100-120	100-160
1.125mm (.0442in)	80	80-100	80-100	80-100	100-120	100-120	100-160
1.15mm (.0452in)	80	80-100	80-100	80-100	100-120	100-120	100-160
1.20mm (.0472in)	80	80-100	80-100	80-100	100-120	100-120	100-160
1.25mm (.0492in)	80	80-100	80-100	80-100	100-120	100-120	100-160
1.30mm (.0511in)	80	80-100	80-100	80-100	100-120	100-120	100-160
1.40mm (.0551in)	80	80-100	80-100	80-100	100-120	100-120	100-160
1.50mm (.0590in)	80	80-100	80-100	80-100	100-120	100-120	100-160
1.60mm (.0629in)	80	80	80-100	80-100	100-120	100-120	100-160
1.70mm (.0669in)	80	80	80-100	80-100	100-120	100-120	100-160
2.00mm (.0787in)	80	80	80-100	80-100	100-120	100-120	100-160
2.20mm (.0866in)	80	80	80-100	80-100	100-120	100-120	100-160
2.50mm (.0984in)	80	80	80-100	80-100	100-120	100-120	100-160
3.00mm (.1181in)	80	80	80-100	80-100	100-120	100-120	100-160

Metric Carbide Saws Standard Tooth Configuration

OD ID	15mm 5mm	20mm 5mm	25mm 5mm	25mm 8mm	30mm 5mm	30mm 8mm	40mm 10mm
16-48	20-64	20-80	20-80	30-100	30-100	30-100	40-100
16-48	20-64	20-80	20-80	30-100	30-100	30-100	40-100
16-48	20-64	20-80	20-80	30-100	30-100	30-100	40-100
16-48	20-64	20-80	20-80	30-100	30-100	30-100	40-100
16-48	20-64	20-80	20-80	30-100	30-100	30-100	40-100
16-48	20-64	20-80	20-80	30-100	30-100	30-100	40-100
16-48	20-64	20-80	20-80	30-100	30-100	30-100	40-80
16-48	20-60	20-64	20-64	30-100	30-100	30-100	40-80
16-48	20-60	20-64	20-64	30-100	30-100	30-100	40-80
16-48	20-60	20-64	20-64	30-100	30-100	30-100	40-80
16-48	20-60	20-48	20-48	30-100	30-100	30-100	40-80
16-40	20-48	20-48	20-48	30-100	30-100	30-100	40-80
16-40	20-48	20-48	20-48	30-100	30-100	30-100	32-70
16-40	20-48	20-48	20-48	30-100	30-100	30-100	32-70
16-40	20-48	20-48	20-48	30-100	30-100	30-100	32-70
16-40	20-48	20-48	20-48	30-100	30-100	30-100	32-64
16-40	20-48	20-40	20-40	30-100	30-100	30-100	32-64
16-32	20-40	20-48	20-48	30-100	30-100	30-100	32-64
16-32	20-32	20-48	20-48	30-100	30-100	30-100	32-64
16-32	20-32	20-48	20-48	30-100	30-100	30-100	32-64
16-32	20-32	20-40	20-40	30-100	30-100	30-100	32-64
16-32	20-32	20-40	20-40	30-100	30-100	30-100	24-48
16-32	20-32	20-40	20-40	30-100	30-100	30-100	24-48
16-32	20-32	20-40	20-40	30-100	30-100	30-100	24-48
16-32	20-32	20-40	20-40	24-100	24-100	24-100	24-48

NUMBER OF TEETH

Typical Width Tolerance: +/- .0002in (.005mm)

NUMBER OF TEETH

Typical Width Tolerance: +/- .0002in (.005mm)



6 Old Stage Road,
Westfield MA, 01085
www.GenSwiss.com

Contact Us For:

- Live Tooling for Citizen, Star, Tsugami & Tornos
- Premium Swiss-Type Cutting Tools by UTILIS
- The Original Swiss Rotary Broaching System
- Industry Leading Thread Whirling Products
- Specialized Tooling & Accessories for Swiss Machines